



VT18-EXT Shown



APPLICATIONS

- Automotive
- Beverage
- Building Supplies
- Consumer Goods
- Contract Packaging
- Food
- Health & Beauty
- Material Handling
- Printing & Publishing

The VT Series shrink tunnel features a heavy duty wire mesh belt conveyor designed to produce high quality shrink packages for retail display. A variety of standard features offer trouble-free, reliable operation: a large viewing window with an illuminated shrink chamber and double insulation to ensure consistent shrinkage and energy efficiency.

This well-insulated shrink tunnel offers variable upper and lower air velocity controls, a variable speed conveyor system and a consistently controlled shrink chamber temperature. The shrink chamber utilizes convection heating instead of a recirculating style heat system. The positive temperature control and the swirling effect of the air velocity from the (vane) fan blades ensures uniform shrinkage.

The VT models are manufactured in the USA in accordance with Arpac's Lean Manufacturing Process (AM²) to ensure quality, performance and value.

FEATURES & BENEFITS

- Compact welded steel frame with laser cut components
- Powder coat finish provides a durable scratch resistant surface that prevents corrosion
- Operator side viewing window with illuminated shrink chamber
- Double insulated shrink chamber offers maximum energy efficiency with minimal heat loss
- Convection style heating system provides consistent shrink wrapping
- Variable upper and lower air velocity controls
- Top and bottom Calrod heating elements
- Simple operator controls
- Variable speed conveyor provides flexibility with uniform shrinkage
- Standard heavy duty wire mesh belt
- All-belt options allow hot air to reach all surfaces on the package, producing uniform shrinkage
- Thermocouple temperature control for precise measurement
- Circuit breaker protected components
- 72" tunnel has 6 heat zones for high speed applications
- Standard casters mounted with leveling legs for machine portability

Note: Final Layout May Vary

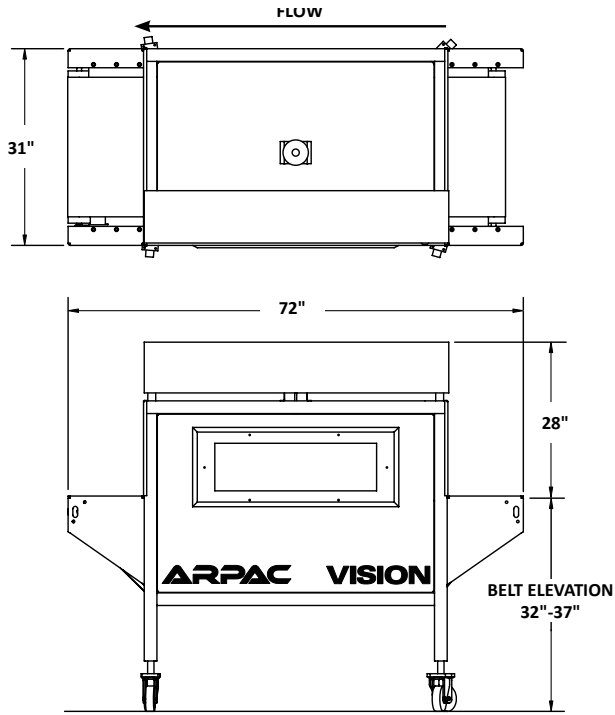

VT18 Shown

OPTIONS

- Optional 480V conversion with step down transformer
- 72" tunnel has 6 heat zones for high speed applications
- Optional Falcon Belt for LDPE film

Model		VT18	VT18-EXT
Total Length		72"	96"
Shrink Chamber Dimensions	Length	48"	72"
	Width	24 3/4"	24 3/4"
	Height	12"	12"
Conveyor Width		22"	22"
Maximum Speed		100 FPM	100 FPM
Fans	Upper	1	3
	Lower	2	3
Standard Voltage		230V	230V
Amps		56A 1Ph 32A 3Ph	67A 3Ph



Optional Guarding Available



Optional Falcon Belt for LDPE Film



Optional Roller Belt

Complete Aftermarket Service & Support for Your Packaging Equipment

SUPPORTPRO™

A DURAVANT SERVICE

Call **844.777.8776** for your regional tech

24/7 Help Available



ARPAC IS A MEMBER OF THE DURAVANT FAMILY OF COMPANIES
 PACKAGING SOLUTIONS | FOOD PROCESSING SOLUTIONS | MATERIAL HANDLING SOLUTIONS | SUPPORTPRO



For more information, please contact your local Lindenmeyr Munroe sales representative.
LindenmeyrMunroe.com