

# HEAVY DUTY COMBO SHRINK SYSTEM



Specification Sheet

MODEL: HDX250

## FEATURES

### CONTROL PANEL

- Conveniently Positioned, **RS-5 Plus** Digital Controller with Three Year Warranty on Original Machine Controller
- Meets UL 508A Standard
- Simple Operation and Precise Temperature Controls
- Cycle Counter Comes Standard with Reset
- Single Cord 220V Single Phase Power Supply

### SEALING AREA

- Hot Knife Exact Seal System with Multiple Profile Options
- Large 17" W by 21" L Seal Area
- Heavy Duty Cast Aluminum Seal Head with Stainless Film Clamps
- Balanced Magnetic Hold Down for Strong, Consistent Seals
- Seal Conveyor with Smooth Product Transfer from Seal Area to Tunnel

### SHRINK TUNNEL

- Non-Stick Mesh Tunnel Belt with Adjustable Riser Bar for Improved Bottom Shrink
- Efficient MaxAir Tunnel Almost Triples the Airflow and Evenly Wraps Air Around Package
- Automatic Cool Down Extends Heating Element Life



HDX250

### OTHER FEATURES

- Package Centering System for Even Shrink - Sealing and Tunnel Conveyor Move in Tandem Vertically. Also, Includes Tunnel Horizontal Quick Slide Adjustment.
- Two Year Warranty
- Four Individually Adjustable Perforating Wheels
- Auto Tensioning Film Cradle
- Heavy Duty Casters and Levelers

**R HS** Denotes RapidHS 5 Day Program Options

## MODEL SPECS

|                                 |   |
|---------------------------------|---|
| <b>FILM CAPACITY</b>            | 22" Wide (56 cm)                                |
| <b>L BAR SEALING AREA</b>       | 17" W, 21" L<br>(43 W, 53 L cm)                 |
| <b>INSIDE TUNNEL DIMENSIONS</b> | 21" L, 16" W, 8" H<br>(53 L, 41 W, 22 H cm)     |
| <b>TUNNEL CONVEYOR SPEED</b>    | 0-20 Feet per Minute<br>(0-6 meters per minute) |
| <b>OVERALL DIMENSIONS</b>       | 82" L, 32" W, 59" H<br>(208 L, 82 W, 150 H cm)  |
| <b>WORKING HEIGHT</b>           | 38" (97 cm)                                     |
| <b>POWER REQUIREMENTS</b>       | 220 Volts, 23 Amp,<br>Single Phase              |
| <b>TUNNEL WATTAGE</b>           | 3,600   |
| <b>WEIGHT</b>                   | 800 lbs. (363 kg)                               |

## AVAILABLE OPTIONS

- Fully Stainless Steel Construction
- Added Heated Hole Punch
- Tunnel Belt Options: Stainless Steel Wire Mesh or PTFE Non-Stick Mesh **R HS**
- Left Hand Reverse Flow
- Spare Parts Kit (5820-012) **R HS**
- Powered Film Unwind with Perforating Roller and 6 Inch High Adjustable Inverting Head
- GTC180/16- 180 Degree Gravity Turn Around Conveyor
- GTC90/16- 90 Degree Gravity Turn Around Conveyor
- AT36- 36" Rotary Accumulator Table
- AT48- 48" Rotary Accumulator Table



# HEAVY DUTY COMBO SHRINK SYSTEM



MODEL: HDX250

## MACHINE FOOTPRINT

|            |   |
|------------|---|
| LENGTH (L) | 82"   |
| WIDTH (W)  | 32" Tunnel Retracted<br>40" Tunnel Pulled Out |
| HEIGHT (H) | 59" Tunnel Lowers 4"                          |

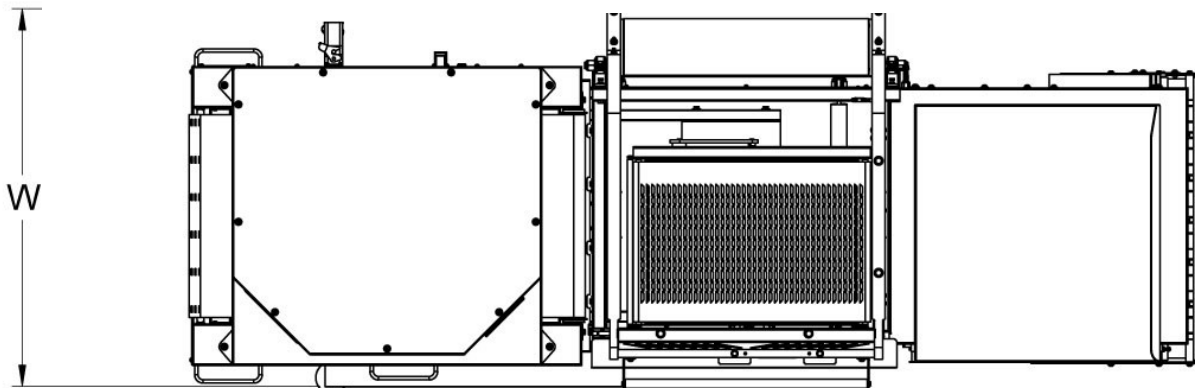
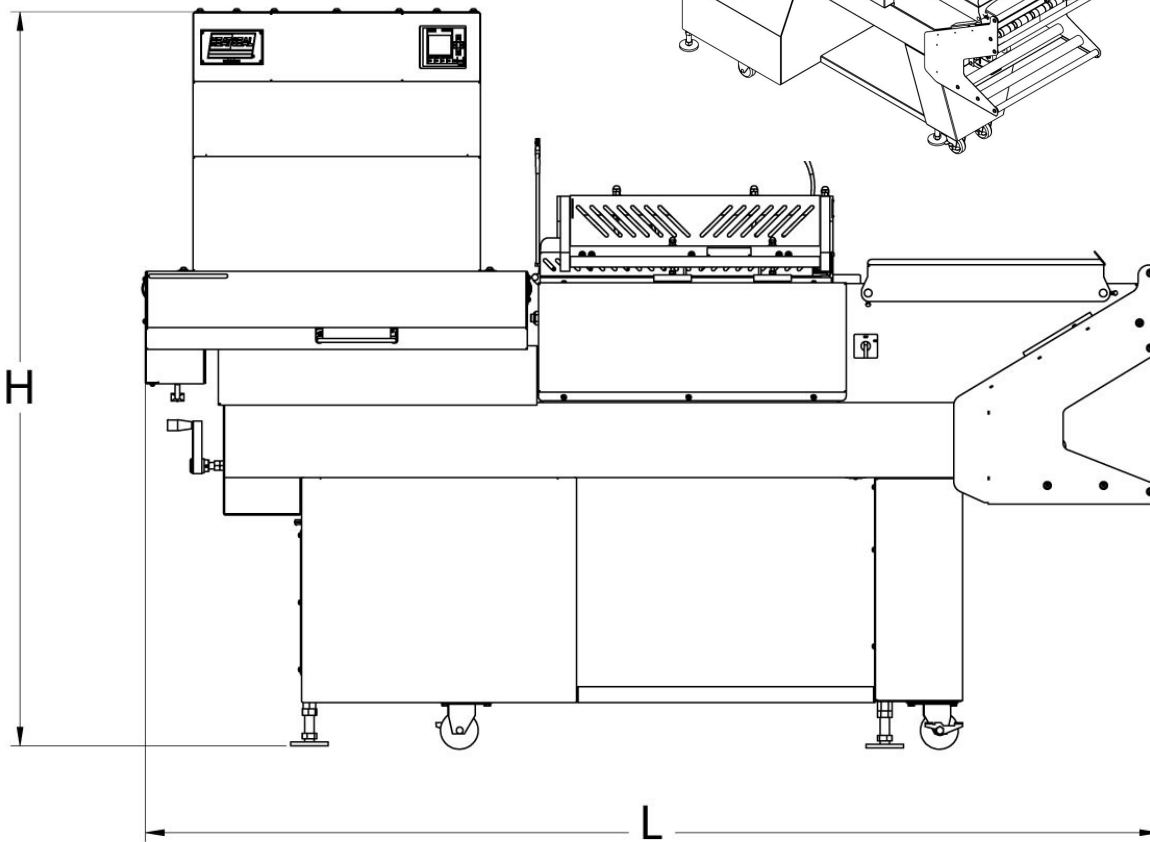
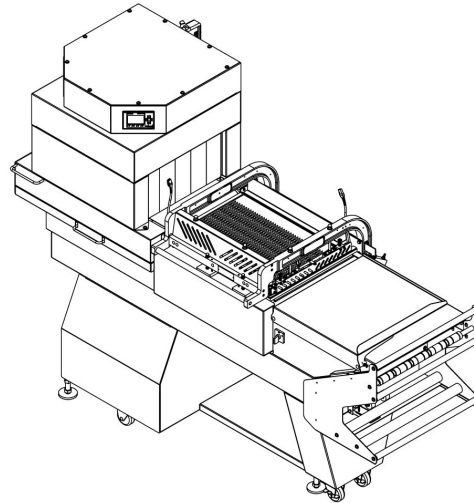

For more information, please contact your local Lindenmeyr Munroe sales representative.

[LindenmeyrMunroe.com](http://LindenmeyrMunroe.com)



Revised 2021