



NVENIA
A DURAVANT COMPANY

PRE-MADE POUCH FILLING MACHINES

Pre-Made Pouch Filling

Model ROFS 1012-HS

The Ohlson Brand Pre-Made Pouch Filling Machines are designed to maximize production output for products being filled in pre-made bags and stand-up pouches.

FEATURES

- Stainless Steel Construction
- Centralized Adjustments For Gripper Width
- User Friendly Color Touch Pad
- Bag Magazine
- Bag Opening Blade With Full Opening Detector
- Bag Deflator
- Discharge Conveyor

Note: All features may not be available for all models



COMMON ACCESSORIES

- Dust collector unit
- Date code printer (Bag samples and desired printing locations must be approved)
- Product Settler
- Gas injection
- Zipper opener assist option
- Product deflator chute
- Locking casters
- Timing gate to improve speed
- Liquid pump/valve for liquids and oils (to be deposited into bag)



INDUSTRIES

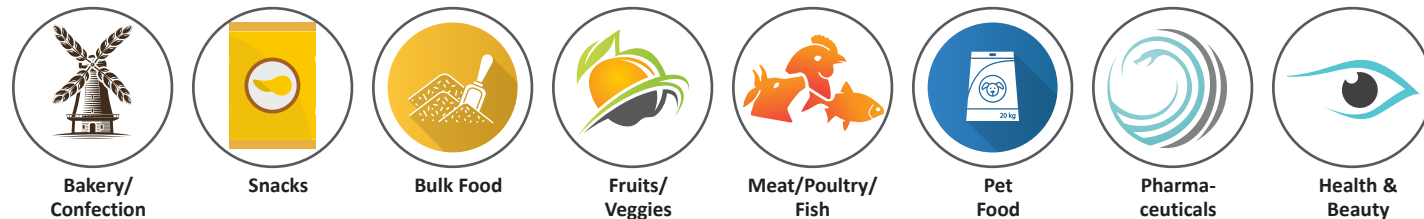

Sample Configuration

ROFS 1012-HS Depicted

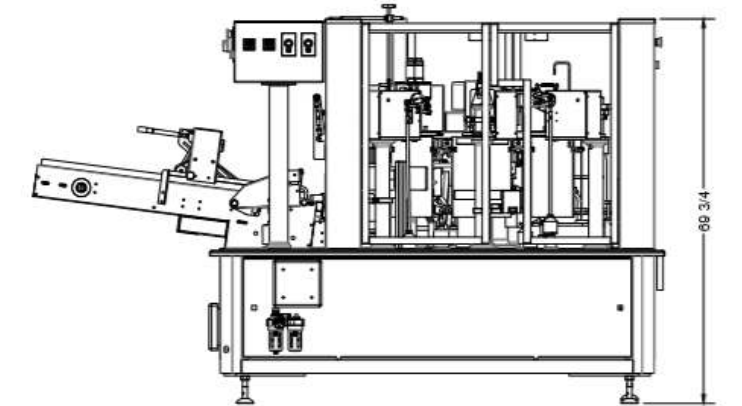
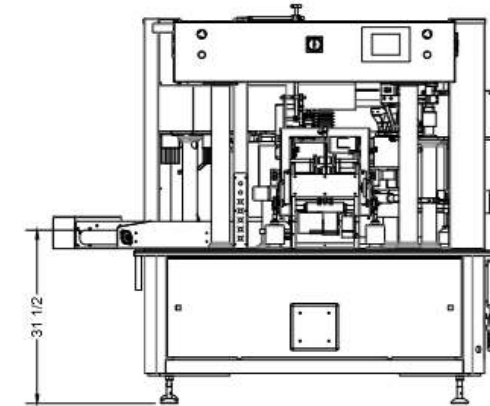
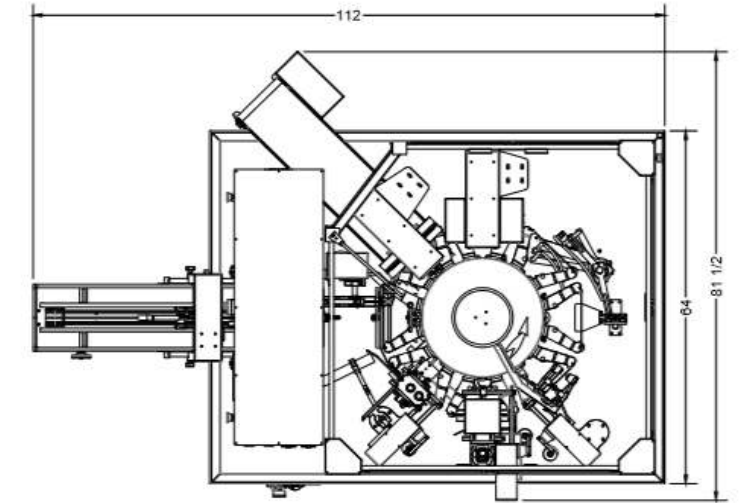
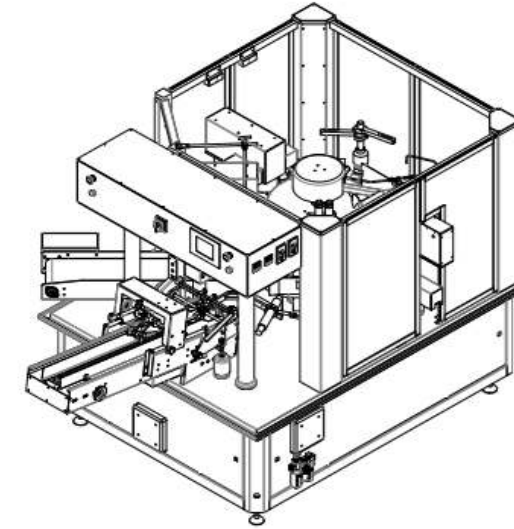

KEY SPECIFICATIONS

Specs may vary based on specific options and/or additional system requirements

	ROFS 1012-HS
Pouch Width	4.3" To 9.8"
Pouch Length	5.9" To 13.7"
Max Weight	5 lbs.
Max Speed*	60 Pouches/Minute
Power Req.	15A 220VAC Three Phase @ 60HZ
Air Req.	18CFM @ 85PSI
Dimensions	112" x 81.5" x 69"

*Final quoted speeds are product and weight-dependent

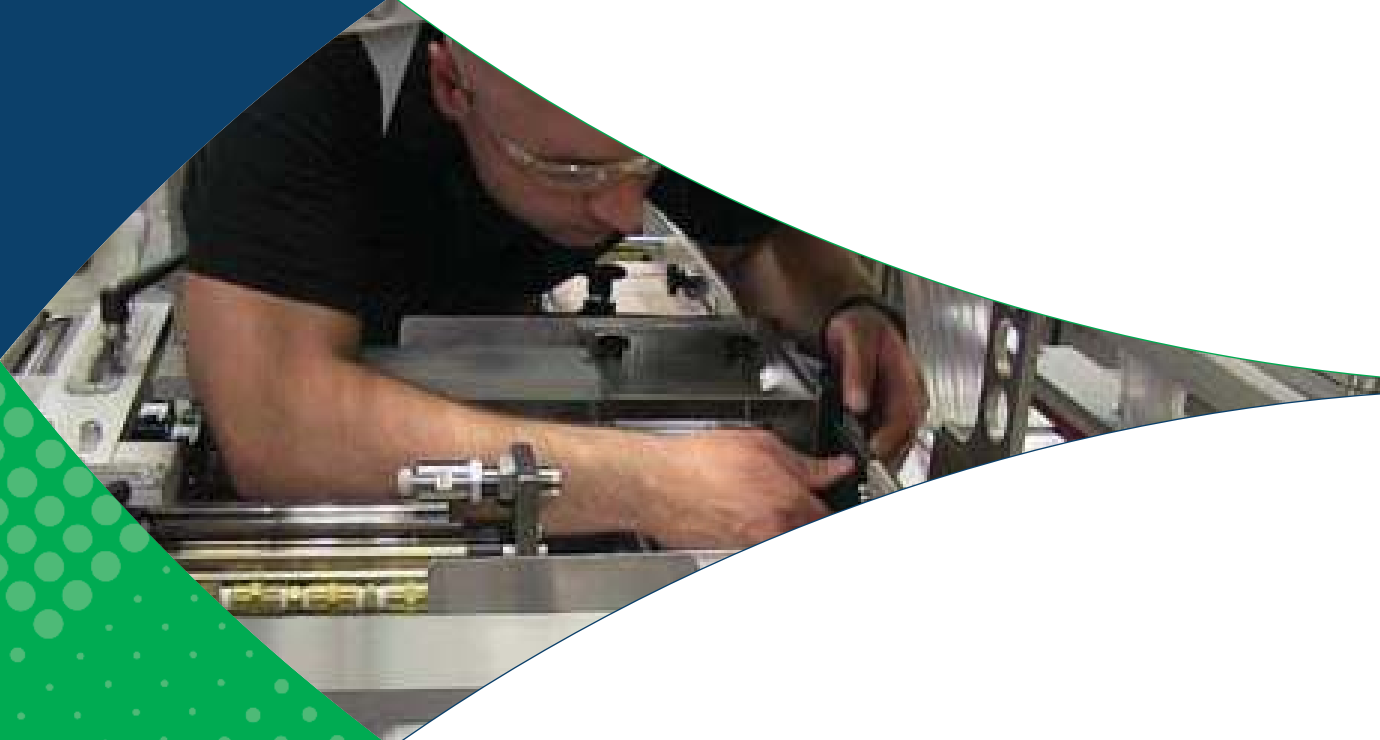

 **Lindenmeyr Munroe**

For more information, please contact your local
Lindenmeyr Munroe sales representative.
LindenmeyrMunroe.com