

ST-2215R SPARTAN

AUTOMATIC L-SEAL WRAPPER

Satisfies the production requirements in a wide variety of applications

The ST-2215R offers the best fit in operations where space is at a premium, where the need is for an automatic wrapper that is simple and easy to operate, or where budget is a primary concern. It will run a wide range of product sizes and, with 20-80 feet per minute conveyors and Texwrap's exclusive Motion Trim™ technology, will satisfy the production requirements in a wide variety of applications.

Designed specifically to compete with lower-priced imports, the Spartan is the most robust of entry-level L-sealers with many features not usually found on machines in this price range. Built right here in the USA, the 2215 retains all the hallmarks of design and proven reliability that Texwrap is famous for and is supported by a nationwide network of highly-trained distributor sales and service specialists.

FEATURES AND BENEFITS

- Space Saving Design
- 115 volt electrics
- Light to medium duty applications
- Simple to operate
- Made in U.S.A.
- Laser-cut, heavy steel-frame construction with durable powder-coat finish
- Maximum film/belt speed 80 FPM for faster throughput
- 115 volt AC power allows the wrapper to be used with a standard wall outlet
- New eye-level, easy-reach film scrap winder with film break alarm
- Compact size allows operation in crowded production areas

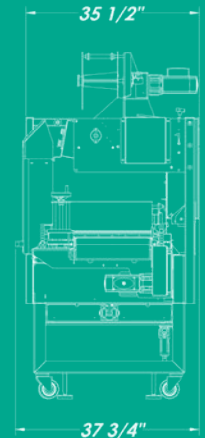
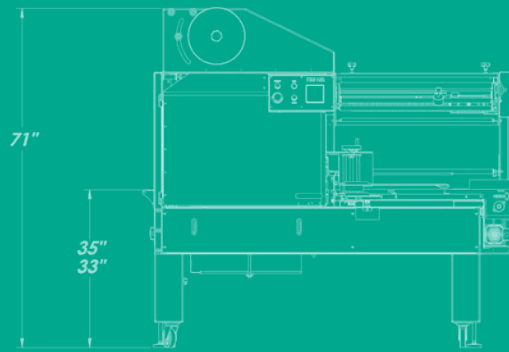
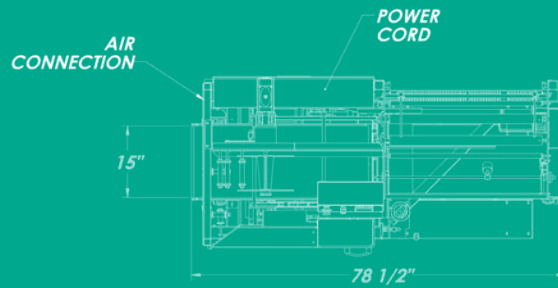
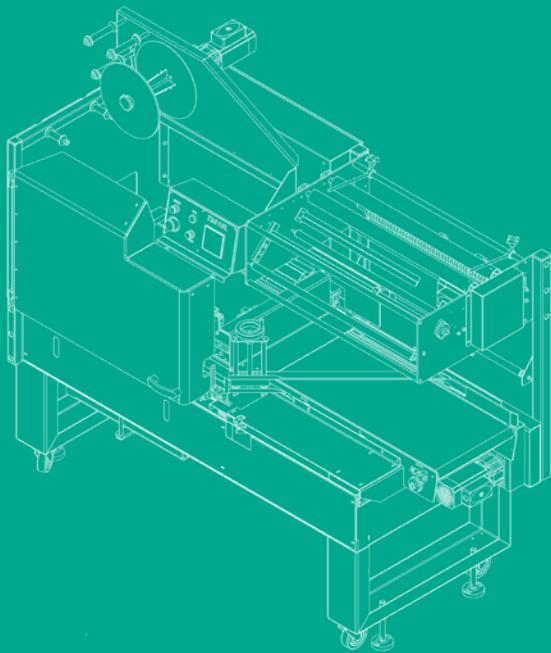

ELECTRICAL REQUIREMENTS: 115 VAC, 15 AMP, GROUNDED OUTLET
AIR REQUIREMENTS: 3 CFM @ 80 PSI

SPECIFICATIONS

- **Conveyor Width:** 15.5"W
- **Cross Seal:** 18.5"W
- **Minimum Pkg Size:** 4"L x 2"W
- **Maximum Pkg Size:** 19"L x 15.5"W x 5"H
- **Film Width:** Maximum 28" folded film
- **Electrical:** 115V, 15 Amp
- **Air Requirements:** 3CFM @ 80 PSI
- **Conveyor Height:** Adjustable from 33" to 35"
- **Maximum PPM:** Up to 30 PPM (dependent on application)

*Specifications on all machines subject to change without notice. Some information may have been updated since the time of publication.

ADDITIONAL FEATURES AND BENEFITS

- Texwrap's exclusive Motion Trim control allows higher production speeds
- "Constant run" capability allows the infeed conveyor to run continuously for faster product feeding
- Mushroom seal with one-piece knife for clean cuts, even in the corner.
- Hand wheel on inverter for easy package height adjustment
- Tool-adjustable seal height
- HMI panel with simple menus for easy operation
- Individual solid-state temperature controls for side and cross seal
- Variable-speed, VFD inverter-duty AC motors
- Independent front and rear bag length settings
- Complete guarding package with safety interlocks
- Microperf pin perforator for precise air evacuation
- Film clamps with safety switches
- Leveling legs with casters